

MiTek Machinery

Service Bulletin

Product(s) Affected Cyber®, Cyber® A/T, SmartSet®, SmartSet® Pro, EasySet®, and CombiSet® Saws

Description Installation of a Wedge Scraper

Date 05/16/2003



MiTek
301 Fountain Lakes Industrial Dr.
St. Charles, MD 63301
Phone (800) 523-3380
Fax (636) 328-9222
www.mii.com

SB 133	
Rev	—
Created by	rr
Reviewed by	
Approved by	gm

Product(s) Affected Cyber[®], Cyber[®] A/T, SmartSet[®], SmartSet[®] Pro, EasySet[®], and CombiSet[®] Saws

Description Installation of a Wedge Scraper

Date 05/15/2003

The enclosed wedge scraper assembly is to be installed on quadrant #3 of MiTek[®] component cutting saws. Figures 1 and 2 show the wedge scraper mounted on a Cyber[®] A/T saw. This Service Bulletin provides detailed instructions on how to mount the assembly onto quadrant #3 of all MiTek component cutting saws.

Table 1: Parts Provided in SB133KIT

PART #	QTY	PART DESCRIPTION
365115	2	Washer, Flat 1/4"
364034	2	Lock Washer, 1/4"
327153	2	Hex Head Screw, 1/4"-20x1/2"
365123	3	Washer, Flat 3/8"
364042	4	Lock Washer, 3/8"
361605	2	Hex Nut, 3/8"-16
327261	4	Hex Head Screw, 3/8"-16x1"
78833 & 34	1	Scraper and Rubber Pad (pre-assembled)
78832	1	Mounting Bracket
78835-501	2 pgs	Drawings

Table 2: Supplies Needed

Measuring Tape	Countersink	Cutting/Tapping Fluid
Center Punch	9/16" Socket	Tap Handle
1/8" Drill	Rags	Small Square
5/16" Drill	Gloves	Pencil or Fine Marker
3/8" Drill	Shop Vacuum	3/8"-16 UNC
Drill Motor	Compressed Air	Hand (Bottom) Tap

Figure 1: Operator's View of Quadrant

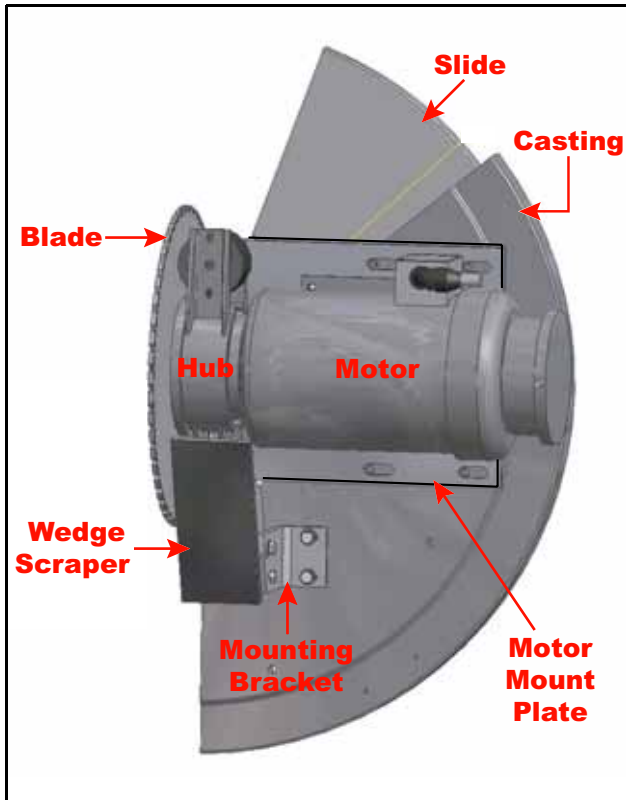
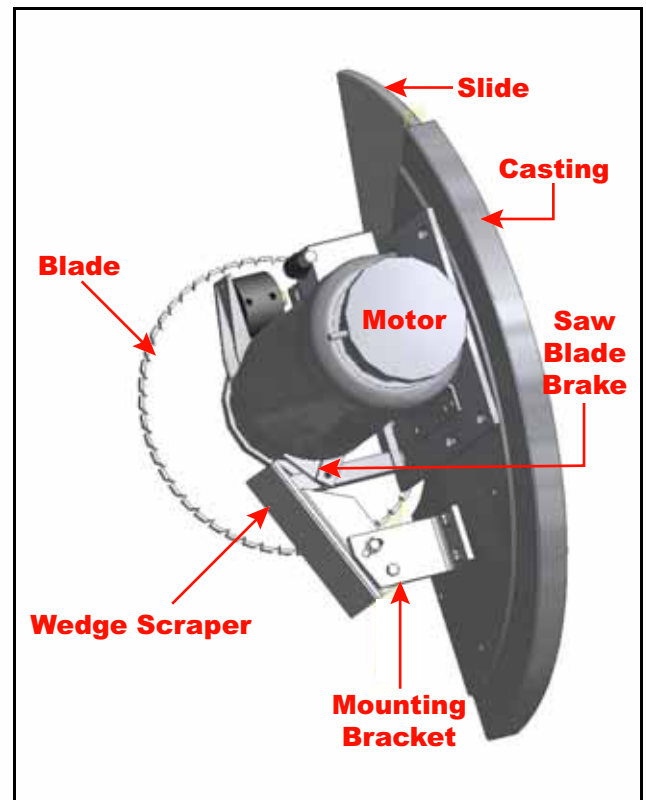

Figure 2: View of Quadrant from the Back



Installation Instructions

If your saw does not have a touch screen, please refer to your equipment manual to determine how to fulfill steps #1-4 manually. If your saw does have a touch screen, you will need to be in "Manual" mode to follow these instructions.

1. Refer to pages 1 and 2 of the attached drawing, 78835-501, for detailed illustrations of the wedge scraper and its position on quadrant #3.
2. Move the carriage hold-down horizontally until it is approximately 30 inches away from the saw blade. On a touch screen, do this by pressing the correct arrow button under *Hold Downs* until the number reads "30".
3. Move the carriage infeed conveyor horizontally until it is approximately 27 inches away from the saw blade. On a touch screen, do this by pressing the correct arrow button under *Infeeds* until the number reads "27".
4. Move the centerline of Blade 3 until the reading or scale shows approximately 10 inches, so the work area is at a comfortable height. On a touch screen, the centerline buttons are the two right buttons under *Blade 3*.



THE BLADE MUST BE AT 95° TO AVOID HITTING THE SLIDE OR OTHER PARTS WHEN DRILLING THROUGH THE CASTING.

5. Adjust the angle of the saw blade on quadrant #3 (the quadrant closest to the operator’s controls) to 95°. On a touch screen, adjust the angle by pressing the left buttons under *Blade 3* until the reading reaches 95°.
6. Move quadrant #4 so it is out of the way by adjusting the blade to approximately 105° with a 15 inch centerline. On a touch screen, choose the “out of cut” position or manually adjust.



ELECTRICAL HAZARD!
ALL ELECTRICAL WORK MUST BE PERFORMED BY A QUALIFIED ELECTRICIAN.
FOLLOW APPROVED LOCKOUT AND TAGOUT PROCEDURES (OSHA 29 CFR 1910.147).

7. Turn off, lockout, and tagout all power to the saw.
 - a) Activate an emergency stop and disconnect all power from the saw at the main power source to the machine. Follow all lockout and tagout procedures to ensure power is disconnected before opening the enclosure.
 - b) Open the main enclosure and verify that all incoming power to the enclosure has been disconnected by using a voltmeter or multimeter set to read “volts”.
 - c) Lockout and tagout the main power switch.
8. Using a pencil or fine-point marker, mark the location of the mounting holes, as seen in Figure 3.
 - a) Measure 2 3/4” from the bottom edge of the motor mounting plate, and mark a line that is parallel to the edge of the plate.
 - b) Measure 4 3/4” from the bottom edge of the motor mounting plate, and mark a line that is parallel to the edge of the plate.
 - c) Measure 5 3/8” over from the edge of the casting, and draw a line parallel to the edge.
9. Use a center punch to mark the two (2) hole locations where the vertical line intersects with the two (2) horizontal lines. They are shown as ⊕ in Figure 3.

Figure 3: Location of Mounting Holes

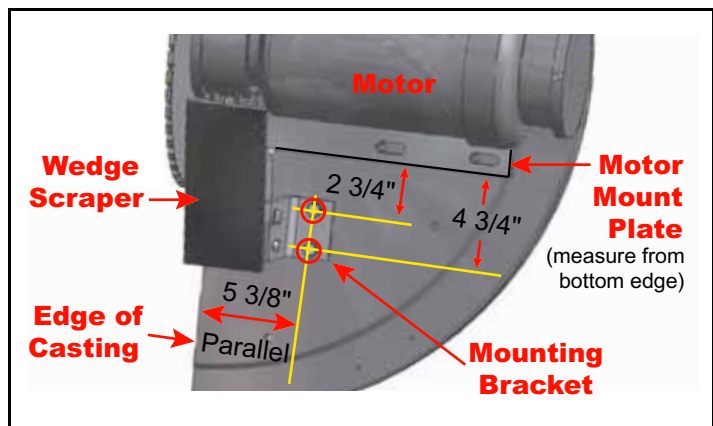

10. Ensure that the drill will clearly miss anything located behind the casting before beginning to drill.
11. Drill a pilot hole completely through the slide with the 1/8" drill at each marked location.
12. Using the 5/16" drill, drill holes at the same two (2) locations, using the pilot holes as guides.
13. Lightly countersink the drilled holes to remove burrs and provide a lead-in for the tap and screw.
14. Tap each hole to full depth using the 3/8"-16 UNC tap.



FAILURE TO REMOVE ALL METAL CHIPS AND FILINGS FROM THE QUADRANT MAY CAUSE DAMAGE TO THE SAW WHICH WILL RESULT IN COSTLY AND TIME CONSUMING REPAIRS.

15. Thoroughly clean both sides of the casting where the mounting holes were drilled.
 - a) Use a shop vacuum to remove all loose metal shavings, chips, and filings.
 - b) Place a rag on the operator's side of the slide and blow compressed air into the two holes.
 - c) Wipe both surfaces with a clean rag to remove any remaining particles.
16. Using the two (2) 3/8"-16x1" UNC hex head screws (PN327261), check that the screws can easily thread into the mounting holes.
17. If they do not easily thread into the holes, use the 3/8"-16 UNC tap to remove any burrs and repeat steps #12-14.
18. Using a 9/16" socket, mount the wedge scraper assembly to the quadrant #3 casting with one 3/8"-16x1" UNC hex head screw (PN327261), a lock spring washer (PN364042), and a flat washer (PN365123) in each hole. See Figure 4.



PROPER ADJUSTMENT OF THE WEDGE SCRAPER IS NECESSARY TO ENSURE THE SCRAPER DOES NOT COME INTO CONTACT WITH THE BLADE. IF THE BLADE HITS THE SCRAPER, CARBIDE TEETH FROM THE BLADE MAY BREAK LOOSE WHICH MAY ENDANGER THE OPERATOR.

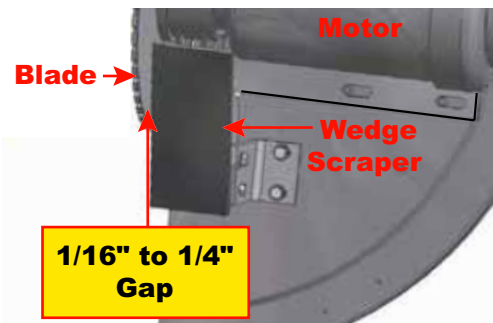

19. The holes in the wedge scraper bracket are slotted to allow for easy adjustment. Allow a 1/16" to 1/4" gap between the edge of the wedge scraper and the back surface of the saw blade, and tighten the screws firmly.

Figure 4: Wedge Scraper Assembly

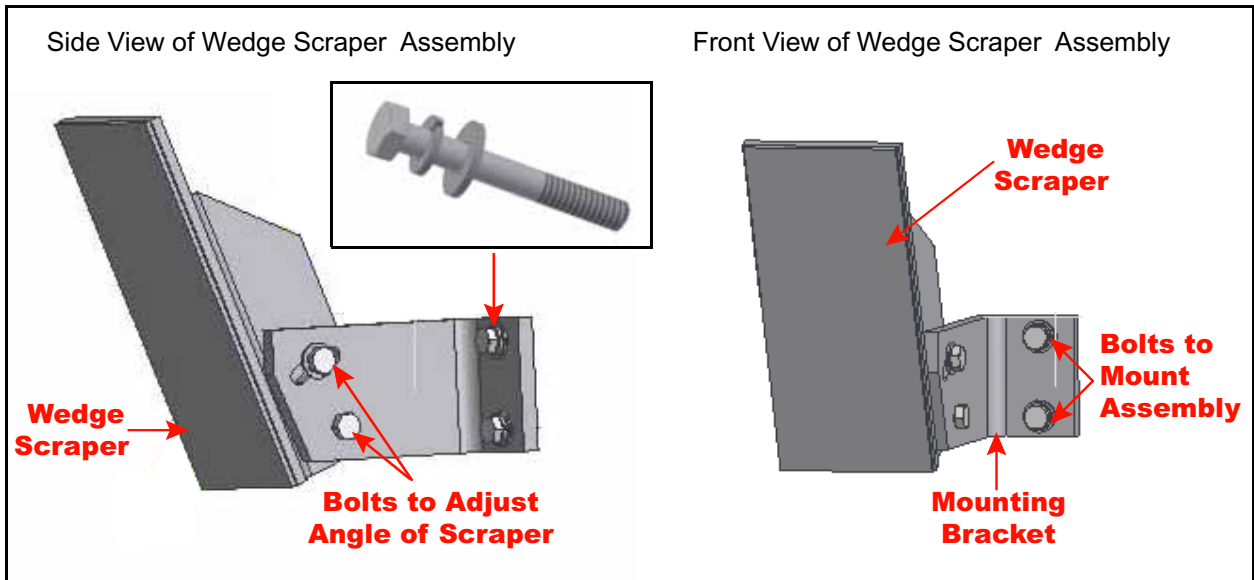

20. Using the 9/16" socket, loosen the two (2) hex head 3/8"-20x1/2" bolts (PN327261) on the wedge scraper, labeled "Bolts to Adjust Angle of Scraper" in Figure 4.
21. Adjust the angle of the scraper so that the back of the wedge scraper plate is near but not touching the saw blade brake mechanism. See Figure 2 for the location of the brake.
22. Retighten the "Bolts to Adjust Angle of Scraper" labeled in Figure 4.
23. While wearing protective gloves, manually release the saw blade brake.
 - a) Take hold of the air supply hose connected to the drain cock closest to the quadrant casting.
 - b) Push the green ring forward while pulling back on the air supply hose.
 - c) Hold the air supply hose tightly to control the direction of the forced air.
24. Using your free hand, spin the blade. If the blade is touching the wedge scraper at any point, adjust the scraper away from the blade by repeating steps #18-19.
25. Reengage the saw blade brake by inserting the air supply hose back onto the drain cock.
26. Ensure that all personnel are a safe distance from all blades, and restore power to the saw.
 - a) Remove the lock and tag on the main power switch in the enclosure.
 - b) Turn on the main power switch in the enclosure, and close the enclosure door.
 - c) Reconnect power at the main power source to the machine.
 - d) Restore power to the touch screen, if applicable.
27. During the first week of operation, inspect the blade on quadrant #3 and the wedge scraper to ensure the wedge scraper is still in place and is not contacting the blade or brake mechanism.